

# KWL1600H Drill

## Technical Data Sheet - Rev 3



November 2008 - MKT1841

Page 1 of 8

### PRODUCT OVERVIEW

The KWL1600H drill is a powerful and versatile drill rig that can be utilized for a large variety of drilling applications. The highest quality hydraulic pumps and motors available have been integrated into this robust design to create a reliable machine that can cope with the toughest conditions. When coupled with the optional KWL RC rod handler this rig is truly a market leader in performance and safety.

Optional Rod Handler (Reverse Circulation)



### DRILLING DEPTH GUIDELINES

Drilling capacities have been calculated from theoretical values of the pull back system with 30% deduction for efficiency losses to arrive at the above capacities.

Therefore these values are indicative only and depend on drilling conditions.

#### CORE DRILLING

DRILL ROD/CORE BARREL	Hole Depth (meters)	Hole Depth (feet)
NQ	2 000	6,562
NQ V-WALL	2 240	7,349
HQ	1 350	4,429
HQ V-WALL	1 647	5,404
PQ	900	2,953
PQ V-WALL	1 170	3,839

#### REVERSE CIRCULATION

DRILL ROD	Hole Depth (meters)	Hole Depth (feet)
4-1/2 inch (114.3 mm)	450	1,476
Hole size: 6-1/2 inch (165.1 mm)		

# KWL1600H Drill

## Technical Data Sheet - Rev 3



November 2008 - MKT1841

Page 2 of 8

### TECHNICAL SPECIFICATIONS

	METRIC SYSTEM	U.S. CUSTOMARY SYSTEM			
<b>MAST</b>					
<b>Design</b>	Fully welded RHS lattice construction with cross bracing				
	Box section mast with 100 mm (3.94") wide drive head wear face/side				
<b>Length (approx)</b>	12.3 m	40.35 feet			
<b>TRAVERSE ACTUATION</b>					
<b>Feed Cylinder Orientation</b>	Barrel to bottom of mast – cylinder in tension during rod pulback				
<b>Head Traverse Length</b>	7.5 m	24.61 feet			
<b>Oil Supply</b>	Oil supply via Denison P16 hydraulic pump				
<b>Traverse Ropes (x2)</b>	20 mm	0.79 inch			
<b>Calculated Aggregate Breaking Load</b>	50.11 t	110,452 lb			
<b>Minimum Breaking Load</b>	39.64 t	87,391 lb			
<b>Retract Force Hydraulic Pressure</b>	310 bar	4,500 psi			
<b>Retract Force at Cylinder</b>	20 500 kg	45,555 lb			
<b>Retract Speed @ 1800 engine RPM</b>	1 087 mm/sec	43 in/sec			
<b>Pull Down Hydraulic Pressure</b>	0 - 207 bar	0 - 3,000 psi			
<b>Pull Down Force</b>	19 237 kg	42,412 lb			
<b>Pull Down Speed Rapid</b>	813 mm/sec	32 in/sec			
<b>Fine Feed Hydraulic Pressure</b>	207 bar	3,000 psi			
<b>Fine Feed Speed</b>	81 mm/sec	3.2 in/sec			
<b>ROTATION DRIVE HEAD</b>					
<b>Model</b>	KWL 1600 (floating spindle)				
<b>Floating Spindle Thread</b>	3-1/2 inch IF RH male				
<b>Floating Spindle Bore</b>	70 mm				
<b>Spindle Thread (Upper)</b>	70 mm 8 TPI LH female				
<b>Drive Motor</b>	Denison M14v axial piston - variable/reversible				
<b>Hydraulic Working Pressure</b>	310 bar	4,500 psi			
<b>Drive Head Side Shift (hydraulic)</b>	457 mm	18 inch			
<b>Drive Head Traveling Plate</b>	Steel with nylon wear strips				
<b>Head Plate Alignment</b>	Adjustable nylon wear blocks at corners				
<b>TORQUE AND RPM RATINGS</b>					
(Based on engine speed of 1,800 RPM)					
	<b>Displacement</b>	<b>Oil Flow</b>	<b>Torque</b>		<b>Output Speed</b>
	in <sup>3</sup> /rev	US•gpm	Nm	lbft	RPM
<b>Core Drilling</b>	14	118	2 100	1,548	925
<b>2.0:1</b>	10	118	1 500	1,106	1250
<b>Reverse Circualtion Drilling</b>	14	118	18 100	13,408	105
<b>16.52:1</b>	10	118	11 363	8,380	157
<b>NOTE:</b> Maximum spindle speed at 14 in <sup>3</sup> hydraulic motor displacement 1200 rpm in high gear. Maximum spindle speed at 10 in <sup>3</sup> hydraulic motor displacement 1300 rpm in high gear. <i>Exceeding these speeds may result in damage to the unit.</i>					

# KWL1600H Drill

## Technical Data Sheet - Rev 3



November 2008 - MKT1841

Page 3 of 8

### TECHNICAL SPECIFICATIONS

	METRIC SYSTEM	U.S. CUSTOMARY SYSTEM
<b>DUMP MAST</b>		
Stroke	2 m	6.56 feet
Locking	Hydraulic cylinder locking system (hands free - vertical to 45°)	
<b>HAUL WINCH</b>		
Haul Winch Travel	11 m	36.09 feet
Drum Diameter	360 mm	14.17 inch
Main Hoist Cable (2160 Casar)	20 mm	25/32 inch
Minimum Breaking Load	39 640 kg	87,391 lb
Aggregate Breaking Load	50 110 kg	110474 lb
Hoisting Capacity	15 059 kg	33,199 lb
Hoisting Speed	1 050 m/sec	41.3 ft/sec
Rope Usable Length	15 m	49 feet
Static Braking	Spring applied/hydraulic release	
Dynamic Braking	Over-center valve	
Hydraulic Pressure	310 bar	4,500 psi
Gear Reduction	Dual double reduction gear drives mounted internally within the drum	
Mounting	Mounted at top of mast	
Over-Wind System	Hydraulic backup system to prevent haul winch over-wind	
<b>WIRELINE</b>		
Drum Capacity		
Cable size 6 mm (0.24")	2 300 m	7,545 feet
Cable size 7 mm (0.28")	1 700 m	5,577 feet
Cable size 8 mm (0.32")	1 300 m	4,265 feet
Cheek Plate Diameter	550 mm	21.65 inch
Drum Width	520 mm	20.47 inch
Drum Diameter	168 mm	6.61 inch
Maximum Working Pressure	310 bar	4,500 psi
Braking	Over-center valve	
Lift Capacity Bare Drum		
Bare Drum	2 650 kg	5,844 lb
Full Drum	883 kg	1,948 lb
Hoist Speed Mid Drum	4 m/sec	157 in/sec
Rope to Table Alignment	Forward tilting drum	
Cable Supplied	1 200 m @ 8 mm	3,937 feet @ 0.32 inch
	or	
	2 000 m @ 6 mm	6,562 feet @ 0.24 inch
<b>HOSE REELER</b>		
	Suspends all drive head traveling hoses, keeping them away from operator and in tension to prevent snaring and hose damage	

# KWL1600H Drill

## Technical Data Sheet - Rev 3



November 2008 - MKT1841

Page 4 of 8

### TECHNICAL SPECIFICATIONS

	METRIC SYSTEM	U.S. CUSTOMARY SYSTEM
<b>BASE FRAME ASSEMBLY</b>		
Length	7.9 m	25.92 feet
Width	2.5 m	8.20 feet
Decking	2 mm chequer plating	
Mast Tilt Cylinders	Dual 152.4 mm bore x 88.9 mm rod (6" bore x 3-1/2" rod)	
Jack Leg Assemblies (x4)	See below	
<b>JACK LEG ASSEMBLIES</b>		
Style	Encased RHS	
Hydraulic Cylinders	107.95 mm (4.25") bore X 1.2 m (3.94 ft) stroke	
Lift Capacity (per leg)	19 950 kg	43,982 lb
Fixing	Welded to main base frame	
Locking	Over centre valves	
<b>POWER PACK</b>		
Engine	Caterpillar CATC13	
Electrical System	24 Volt	
Braking @ 1800 RPM	328.2 kW	440 HP
Engine Speeds	700 - 1800 RPM	
Torque @ 1400 RPM	2010 Nm	1482.5 lb/ft
Engine Speeds (Diamond Drilling)	1200 - 1800 RPM	
Estimated Fuel Burn	20 - 24 L/hr	5 - 6 gal/hr
Air Filtration	Donaldson® FVG16-0152 with safety element	
Pump Group	Dual funk pump drive 59000 series (2 Denison P16 pump groups)	
Hydraulic Piston Pump Group	Denison triple vane - rotation (water pump, servo, spare)	
Hydraulic Vane Pump Group	Denison triple vane - rapid feed (rod handler, auxilliary, hydraulic cooler fan)	
Hydraulic Oil Filtration	Main return filter and case drain filter	
Other	Engine sump remote drain line Funk drive remote drain line Thermal covers for exhaust	
<b>CONTROL CONSOLE</b>		
Position	L/H rear corner of rig base	
Extension	800 mm (31.5") travel to facilitate visibility of work table whilst angle drilling	
Yaw	Cabinet slews 30° away from mast to facilitate visibility of work table	
Gauges	65 mm (2.56") gauges to monitor all hydraulic pressures	
Console Access	Hinged access doors both sides of console	
Platform	Fold up 'jump up stand' for operator	
Layout	All controls and gauges ergonomically positioned for operator comfort	
Pilot Control Lever Functions	Rapid feed, rotation, haul winch, wireline winch	
Auxiliary Valves	Danfoss PVG 32 L/S	

# KWL1600H Drill

## Technical Data Sheet - Rev 3



November 2008 - MKT1841

Page 5 of 8

### TECHNICAL SPECIFICATIONS

	METRIC SYSTEM	U.S. CUSTOMARY SYSTEM
<b>CONTROL CONSOLE (cont'd)</b>		
<b>Main Load Sense Control Valve</b>		
Rapid feed	Denison Lokomec CVG31	
Rotation, haul winch and wireline winch	Denison Lokomec CVG33	
<b>Water Pressure</b>	Panel mounted, 0-3000 psi	
<b>Torque controller (multi-purpose)</b>	Controls torque for forward rotation, haul winch lift, wireline winch lift	
<b>Labels</b>	Stainless steel engraved and riveted to cabinet facia	
<b>SAFETY CAGE</b>		
<b>Style</b>	1.5 m (4.92 ft) high, pipe framed, mesh covered – guards worktable and drive head (when fully lowered)	
<b>Safety cut-out</b>	Opening cage restricts oil flow to drive head motor thus limiting rod rotation speed	
<b>FOOT CLAMP</b>		
<b>Brand</b>	KWL hydraulic foot clamp	
<b>Jaws</b>	PQ/HWC, HQ and NQ (one set of jaw holders supplied for use with HQ and NQ jaws)	
<b>WATER PUMP</b>		
<b>Water Pump</b>	FMC L1118 DISC	
<b>Water Pump Pressure</b>	34.5 bar	1500 psi
<b>Fluid Delivery</b>	264 Lpm	65 US gpm
<b>Hydraulic Drive Motor</b>	Volvo F12-110	
<b>Drive Coupling</b>	Fenner Rubber Tyre	
<b>Pressure Gauge</b>	Analogue read out in gallons (located in control console)	
* Location above or below deck depends on carrier chassis width		
<b>HYDRAULIC OIL COOLER</b>		
<b>Brand/Model</b>	Dyna Cool 35/15	
<b>Hydraulic Oil Heat Rejection</b>	45 kW	2,560 BTU/min
<b>HYDRAULIC HOSES AND FITTINGS</b>		
<b>Hose Type</b>	Aeroquip	
<b>Fittings (subject to availability)</b>	Aeroquip and Ryco	
<b>POWER BREAKOUT STD</b>		
<b>Type</b>	Cylinder actuated mounted on lower right hand side of mast	
<b>Tool</b>	Wrap around spanner	

# KWL1600H Drill

## Technical Data Sheet - Rev 3



November 2008 - MKT1841

Page 6 of 8

### TECHNICAL SPECIFICATIONS

	METRIC SYSTEM	U.S. CUSTOMARY SYSTEM
<b>AIR/FLUID MANIFOLD</b>		
<b>Valves</b>	50.8 X 50.8 mm (2 x 2 inches) Worchester valves with high temp seals	
	1 x actuated manually	
	1 x actuated hydraulically	
<b>Air Inlets</b>	Auxiliary and booster	
<b>Air Outlets</b>	Fitted with directional elbows to vent air away from operator	
<b>ACOUSTIC COVER</b>		
<b>Location</b>	Encloses engine and engine cooler	
<b>Access</b>	Door left of vent doors	
<b>Material</b>	Metal with high grade acoustic insulation inlayed	
<b>Belly Plate</b>	Removable	
<b>ADDITIONAL SAFETY FEATURES</b>		
	Guards on all couplings and fans	
	Hose socks on all high-pressure air hoses fix to anchor points	
	Hand railing around drillrig base (N/A if rod bin)	
	Access steps mounted into rig base (2 locations)	
	Safety signage	
<b>FIRE SUPPRESSION</b>		
<b>Description</b>	NPF fire suppression system mounted inside acoustic	
<b>Activation</b>	Two (2) manual activation points and automatic thermal activation	
<b>FINISH</b>		
	All steel sand blasted prior to undercoating	
	Undercoat and topcoat - polyurethane two pack paint	
<b>MANUALS</b>		
<b>Operators (x2)</b>	Standard operating and safety procedures	
<b>Spare Parts (x2)</b>	Boart longyear manufactured components and hydraulic circuits	
<b>WARRANTY</b>		
	Six (6) months against faulty workmanship	
	Individual manufactures warranty on all componentry as per our terms and conditions of sale	
<b>COMMISSIONING</b>		
	Upon commencement of normal drilling operations, BLY to coordinate on-site commissioning with client	
	Travel and accommodation costs at clients expense	

# KWL1600H Drill

## Technical Data Sheet - Rev 3



November 2008 - MKT1841

Page 7 of 8

### TECHNICAL SPECIFICATIONS

	METRIC SYSTEM	U.S. CUSTOMARY SYSTEM
<b>OPTIONS</b>		
<b>KWL Rod Handler (Reverse Circulation)</b>	Inclusion of a rod handler typically requires the following:	
	Tilting rod bin	
	Mast rod tray	
	Standard hand railing removed or modified	
	<b>Mast ladder MUST be removed</b>	
<b>Tilting Rod Bin</b>	Recommended if rod handler is fitted	
	This includes rod bin verniers, tilt plates, head board and associated hydraulics	
	Vernier tubes are included in standard base frame structure enabling this to be retro fitted at a later date	
<b>Mast Rod Tray</b>	Required if rod handler is fitted	
	Fitted into the mast, this supports the drill rod to facilitate alignment during make/break actions while using a rod handler	
	Mounting points are included in standard mast frame structure enabling this to be retro fitted at a later date	
<b>Ladder</b>	Mounted on right hand side of mast	
	Fitted with Lanyard rope that allows a harness to be attached for ascending mast when vertical	
	<b>Not available if a rod handler is fitted to the rig</b>	
<b>Fuel Tanks</b>	1000 L (264 US gal) deck mounted fuel tank mounted behind mast rest	
	540 L (143 US gal) alloy round mounted to truck chassis rail, depending on available space	
<b>Drilling Platform</b>		
Base	Folds up for rig transport when mast is lowered	
Width	1 825 mm	71.85 inch
Length	2 065 mm	81.30 inch
<b>Rig Lighting</b>	Tower mounted floodlights (x 4)	
	Console light (x 1)	
	High amperage alternator (customer's choice)	
<b>Rod Spinner</b>		
Brand	UDR	
Rod Sizes	BQ NQ HQ PQ	
Extension Subs	BQ NQ HQ PQ	
Mounting	Lower right hand side with swing in /out	

# KWL1600H Drill

## Technical Data Sheet - Rev 3



November 2008 - MKT1841

Page 8 of 8

### DIMENSIONS AND WEIGHTS\*

#### WEIGHT

Weight = 21 000 kg (46,297 lb)

#### Consisting of:

- Mast
- Hydraulic Module c/w Control Console
- Haul and Wireline Winch
- Power Pack
- Rotation Drive Head
- Base Frame Assembly
- Safety Cage
- Acoustic Cover
- Foot Clamp
- Water Pump

#### DRILL - TOP VIEW

- a = 2 500 mm (98.42 in)
- b = 1 909 mm (75.16 in)
- c = 7 900 mm (311.02 in)
- d = 2 684 mm (105.67 in)

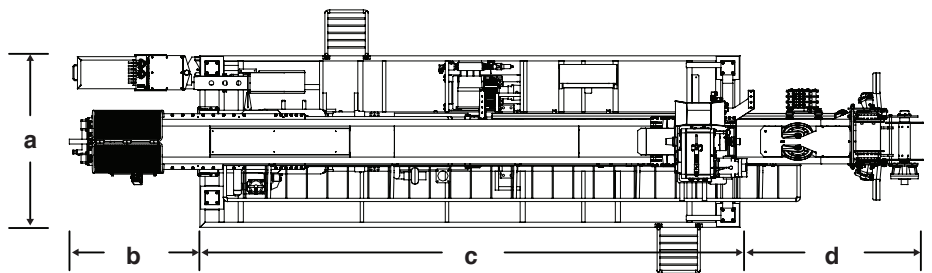

#### DRILL - SIDE VIEW

- a = 12 494 mm (491.89 in)
- b = 3 232 mm (127.24 in)
- c = 554 mm (21.81 in)
- d = 1 250 mm (49.21 in)
- Jack Leg extended
- e = 3 237 mm (127.44 in)
- f = 1 145 mm (45.08 in)
- g = 2 812.5 mm (110.73 in)

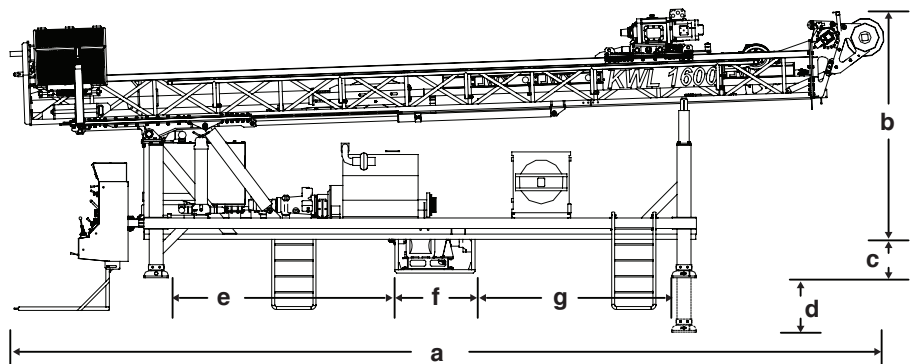

#### Rig Carrier (by Client)

The standard KWL1600H drill is designed to suit a Tatra T815, 8x8, long wheel base unit. Selection of an alternate carrier should be done in conjunction with the above diagram to ensure wheels, fuel tanks, transmission, suspension and other 'furniture' will not foul with the rig jack legs. A minimum chassis specification will need to be met prior to the rig being mounted to it. Additionally, care should be taken that weight and dimensional envelopes are in accordance with local statutory vehicle guidelines. In some instances, permits may be required.

**NOTE:** Mounting the rig to tracks is non-standard, please contact your Boart Longyear representative.

\* Dimensions and weights may vary depending on options and should be checked before crating or lifting.